

Grinder Guard & Grit Grabber

Maximizing Safety and Productivity



VALUE is the Biggest Benefit

The Grinder Guard from Midaco is designed to fit virtually ALL pedestal or bench grinders which translates into maximum versatility and long shop life. Reduce Liability Exposure and Increase Worker Safety Protection with Midaco's Grinder Guard.

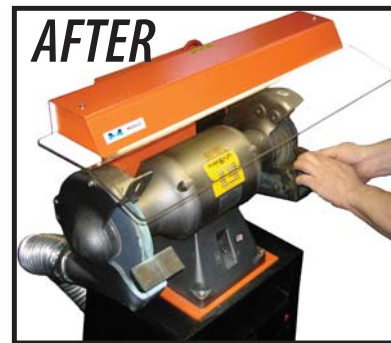

- 27" Lexan Impact Resistant Visor
- Heavy Gauge Steel
- OSHA Orange
- Permanent Mounting
- Full Width Fluorescent Lighting

Grinder Guard Features:

Features	Advantage	Benefit
27" Full Width Visor	Protects at least 6 times more area (128 sq. inches)	Allows safe viewing from more angles
Replaceable Impact-Resistant Visor	Maximum protection from sparks and dust.	Stays clear longer
Full-Width Fluorescent Light	Increased visibility and operator comfort	Ensures greater accuracy and improves productivity
OSHA Orange	Identifies safety area	Impedes corrosion, lasts longer

Grinder Guard Dimensions

Model #46 fits grinders with up to 8" wheels
 Model#46A fits grinders with 9"-12" wheels

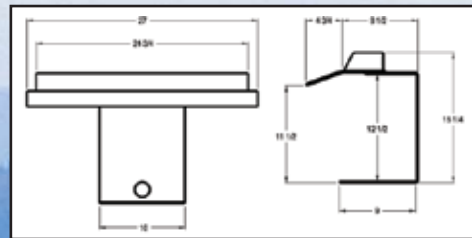

Note: Model #46A dimensions are same, except depth is 14 1/2" and overall height is 19"

*Unit shipped complete with built in 24" fluorescent light and 7 foot cord.

- Fits Pedestal or Bench Grinders
- Built-in Fluorescent Light
- Full Width Protection
- Affordably Priced
- OSHA Orange



Engineered and manufactured in the USA...
Supported throughout the world

Reduce Maintenance Costs and Improve Operator Safety with MIDACO's GRIT-GRABBER Dust Collection System.

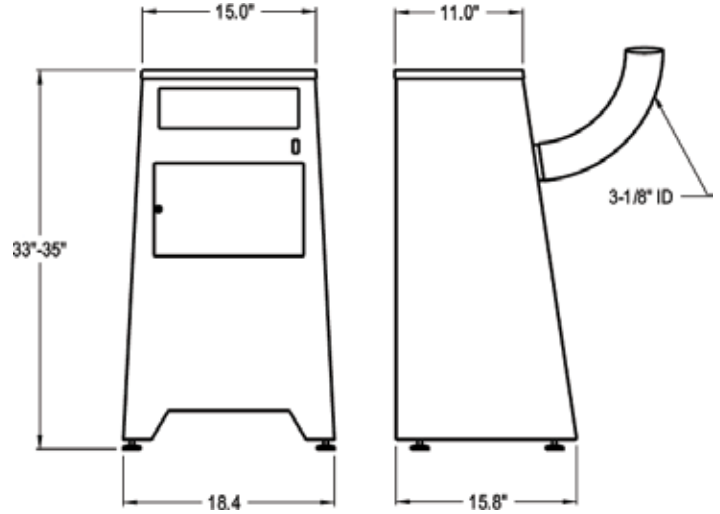

Grit Grabber Model 2000

Features	Advantage	Benefit
Heavy Duty Motor	Sealed bearing industrial motor offers long term service	Minimizes downtime and maintenance costs
Replaceable Filter Element	Easily replaced filter traps vacuumed debris	Reduces operator hazards, improves shop cleanliness
Universal Hose and Clamps	Durable hose, built to last, fits all models	Easy to retrofit, saves labor and time
Illuminated ON-OFF Switch	Red LED safety light indicates unit is on	Promotes longevity in noisy environments
Compact, Vibration-Free Design	Insulated enclosure operates with low noise level in 70dp (A) range	Utilizes available space and promotes safety
Installation Options	Self leveling feet or stationary mount	Allows multiple department or fixed position usage
CFM Exhaust Level Exceeds OSHA's Minimum	As specified by OSHA ventilation standard 1910.94 up to 10" diameter	Maximizes operator safety and productivity

Performance & Durability are the Big Benefits.

The Grit-Grabber and Grinder Guard are designed for the use with virtually ALL grinders and buffers. The universal design offers significant advantages in installation, operator safety, productivity and maintenance.

Easy to Order: Phone, Fax, or Mail your Order Today!

Grit-Grabber vacuum pedestal fits 5" to 10" diameter wheels. Includes filter, hoses and clamps. 120 Volts, 60Hz (Grinders and guards are additional)

Replacement Filters

No. GF2006 (6 per case)

Grinder Guard

Model 46 (up to 7" diameter, wheels)
Model 46A (8" to 12" diameter, wheels)

Crystal Clear Visor Cleaner

(recommended for polishing Lexan and other eyeshields)

Since 1969, MIDACO has been a leader in providing innovative and quality solutions to improve manufacturing efficiency for companies worldwide.



MIDACO CORPORATION
2000 EAST TOUHY AVENUE
ELK GROVE VILLAGE, IL 60007 USA
PHONE: 847.593.8420
FAX: 847.593.8451
www.midaco-corp.com

Visit our websight at
www.midaco-corp.com

